

This document is our property and must not under any circumstances be copied in its original or modified state reproduced or used for any unauthorized purpose without our written permission, nor may its contents be imparted to a third party. Contravention will be prosecuted.

PROJE designed
No manual changes

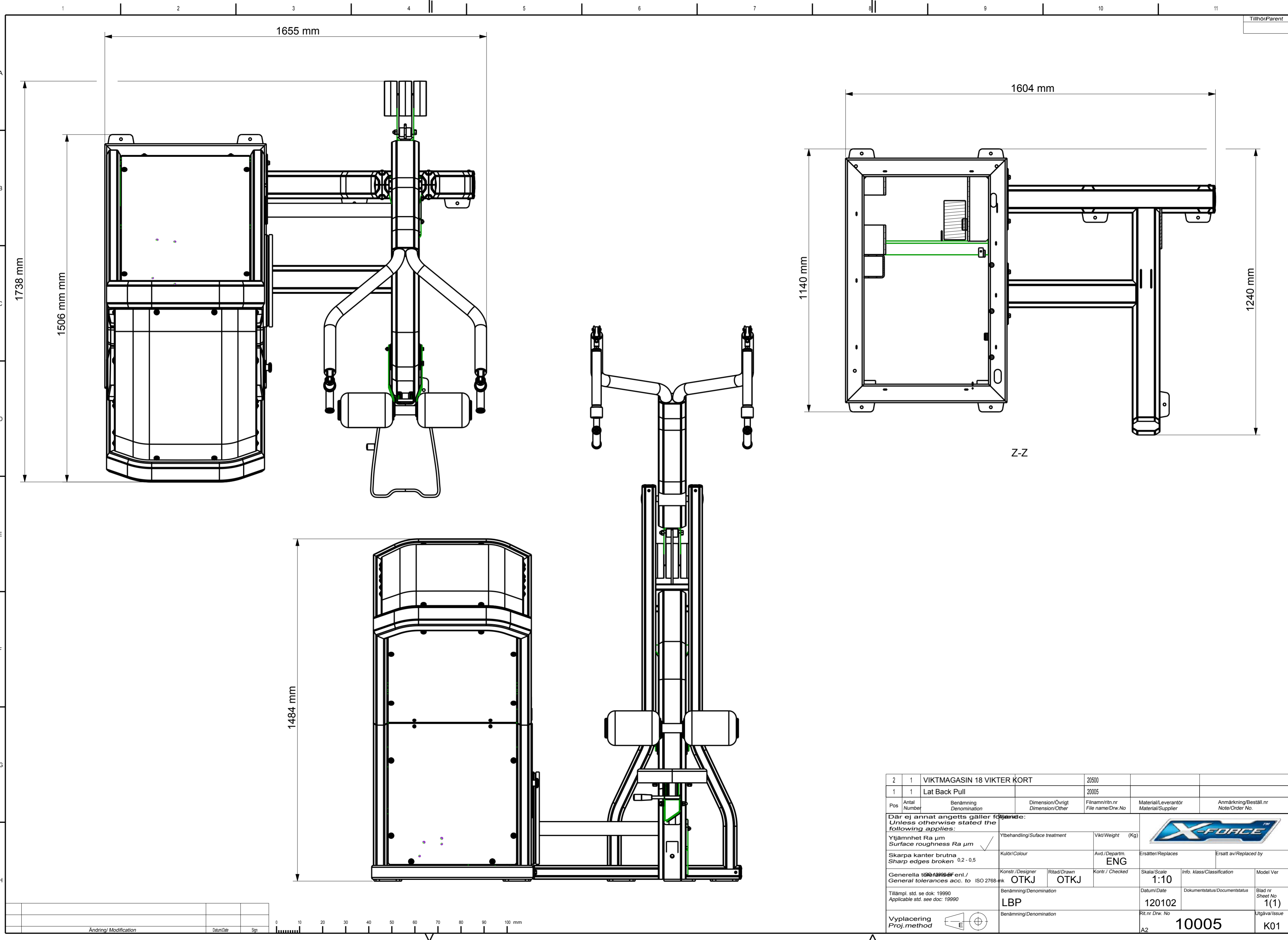

2	1	VIKTMAGASIN 18 VIKTER KORT		20500		
1	1	Lat Back Pull		20005		
Pos	Antal	Benämning	Dimension/Ovrigt	Filnamn/rtn.nr	Material/Leverantör	Anmärkning/Beställ.nr
Number	Denomination	Dimension/Other	File name/Drw.No	Material/Supplier	Note/Order No.	
<p>Där ej annat angetts gäller följande: Unless otherwise stated the following applies:</p>						
Ytjämnhet Ra µm Surface roughness Ra µm		Ytbehandling/Suface treatment	Vikt/Weight (Kg)			
Skarpa kanter brutna Sharp edges broken		Kulör/Colour	Avd./Departm.		Ersätter/Replaces	
0,2 - 0,5		ENG	ENG		Ersatt av/Replaced by	
Generella toleranser enligt ISO 2768-mk General tolerances acc. to ISO 2768-mk			Konstr./Designer	Ritad/Drawn	Kontroll/Checked	Skala/Scale
			OTKJ	OTKJ		1:10
Tillämpl. std. se dok: 19990 Applicable std. see doc: 19990			Benämning/Denomination		Datum/Date	Info. klass/Classification
			LBP		120102	Dokumentstatus/Documentstatus
Vyplacering Proj.method			Benämning/Denomination		Rit.nr Drw. No	Blad nr Sheet No
					A2	10005
						1(1)
						Utgåva/Issue
						K01



Ändring/Modification	Datum/Date	Sign

