

This document is our property and must not under any circumstances be copied in its original or modified state reproduced or used for any unauthorized purpose without our written permission, nor may its contents be imparted to a third party. Contravention will be prosecuted.

PROJE designed
No manual changes

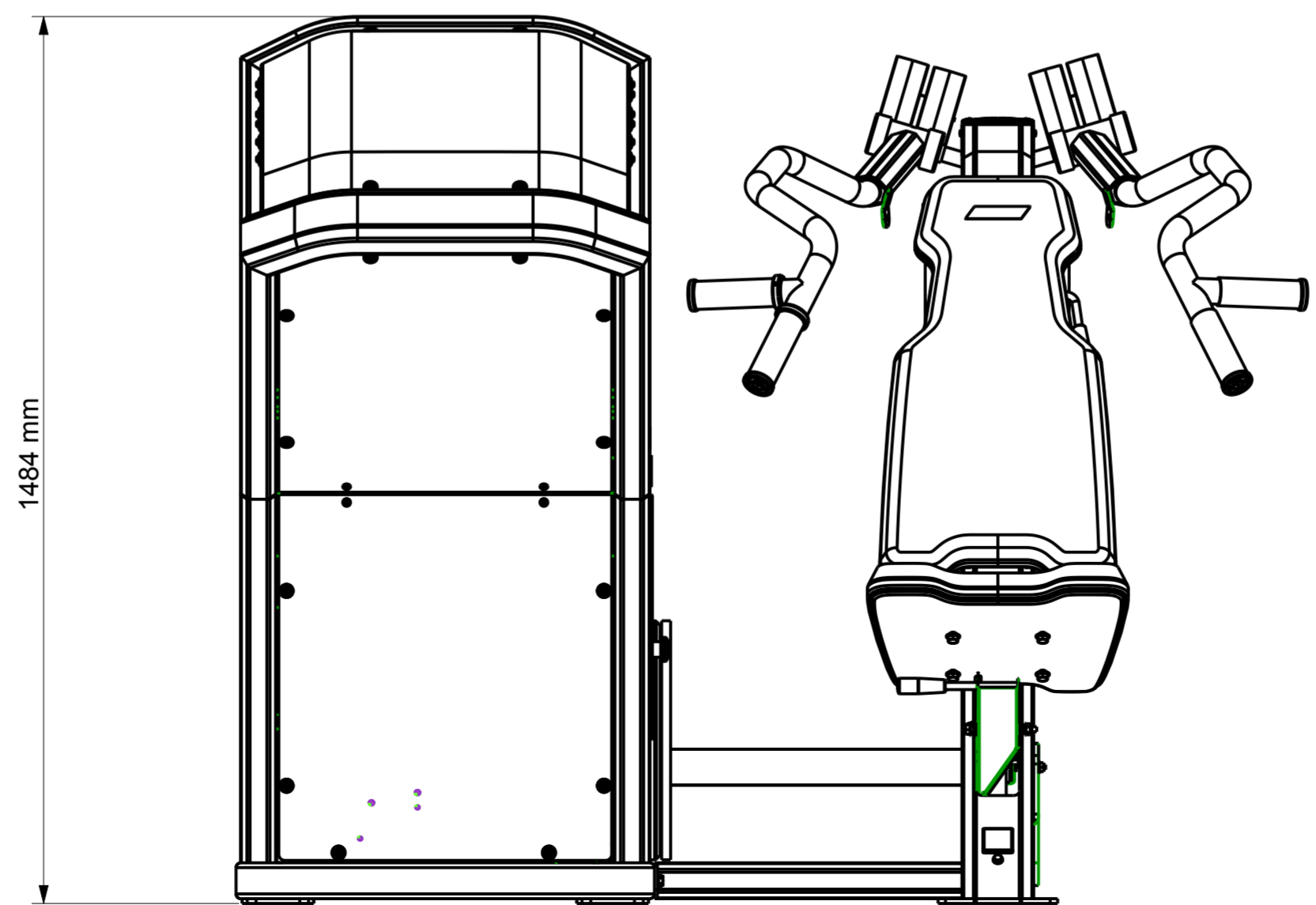

2	1	VIKTMAGASIN 18 VIKTER KORT	20500			
1	1	Pec Angle Press	20009			
Pos	Antal	Benämning	Dimension/Ovrigt	Filnamn/rtn.nr	Material/Leverantör	Anmärkning/Beställ.nr
Number	Denomination	Dimension/Other	File name/Drw.No	Material/Supplier	Note/Order No.	
<p>Där ej annat angetts gäller följande: Unless otherwise stated the following applies:</p>						
Ytjämnhet Ra µm Surface roughness Ra µm		Ytbehandling/Suface treatment	Vikt/Weight (Kg)			
Skarpa kanter brutna Sharp edges broken		Kulör/Colour	Avd./Departm.		Ersätter/Replaces	
0,2 - 0,5		ENG	ENG		Ersatt av/Replaced by	
Generella toleranser enligt ISO 2768-mk		Konstr./Designer	Ritad/Drawn	Kontroll/Checked	Skala/Scale	Info. klass/Classification
Tillämpl. std. se dok: 19990 Applicable std. see doc: 19990		OTKJ	OTKJ		1:10	
Vyplacering Proj.method		Benämning/Denomination		Datum/Date	Dokumentstatus/Documentstatus	Blad nr Sheet No
E		PAP		120102		1(1)
		Benämning/Denomination		Rit nr Drw. No	10009	Utgåva/Issue
				A2		K01

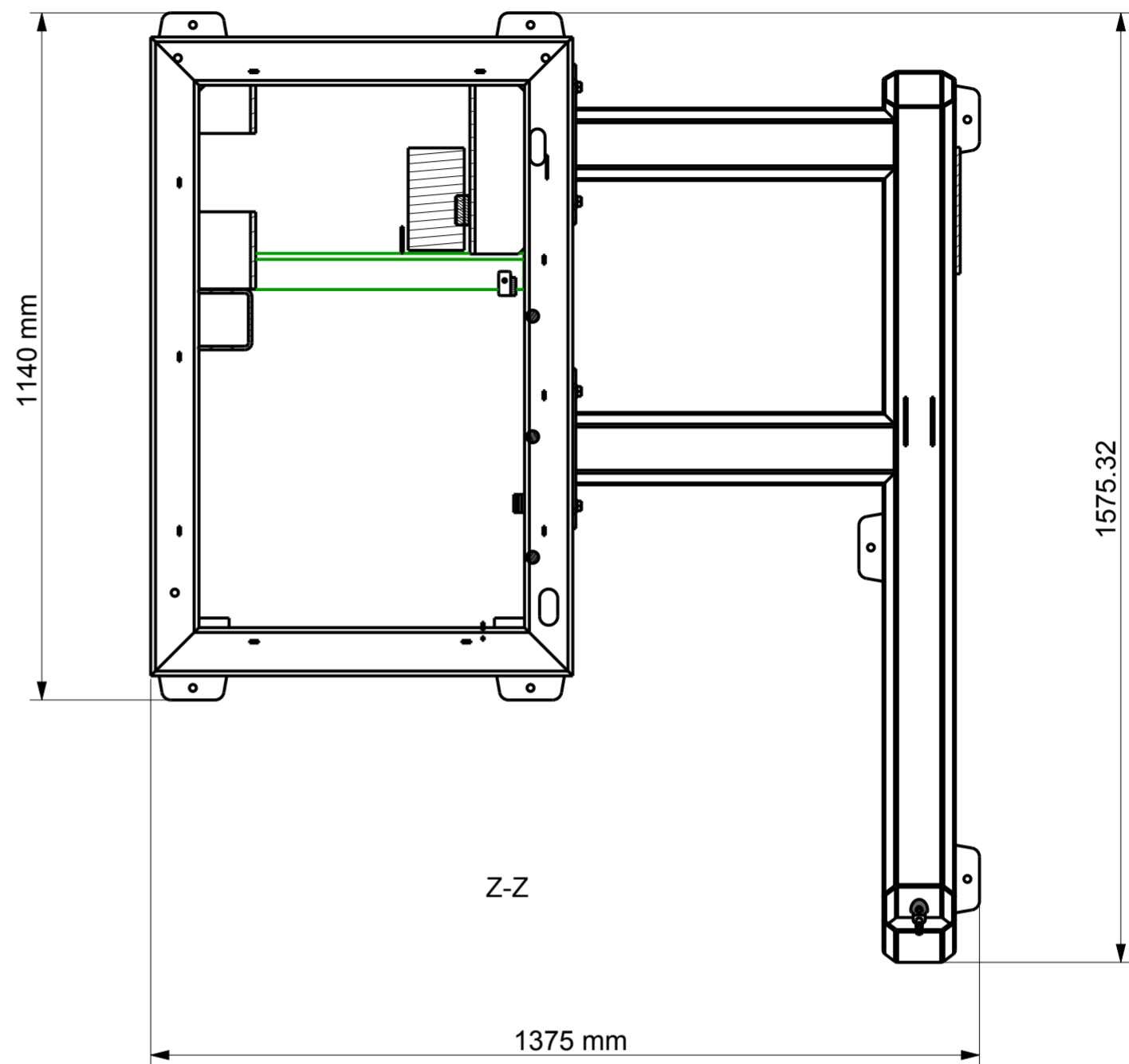
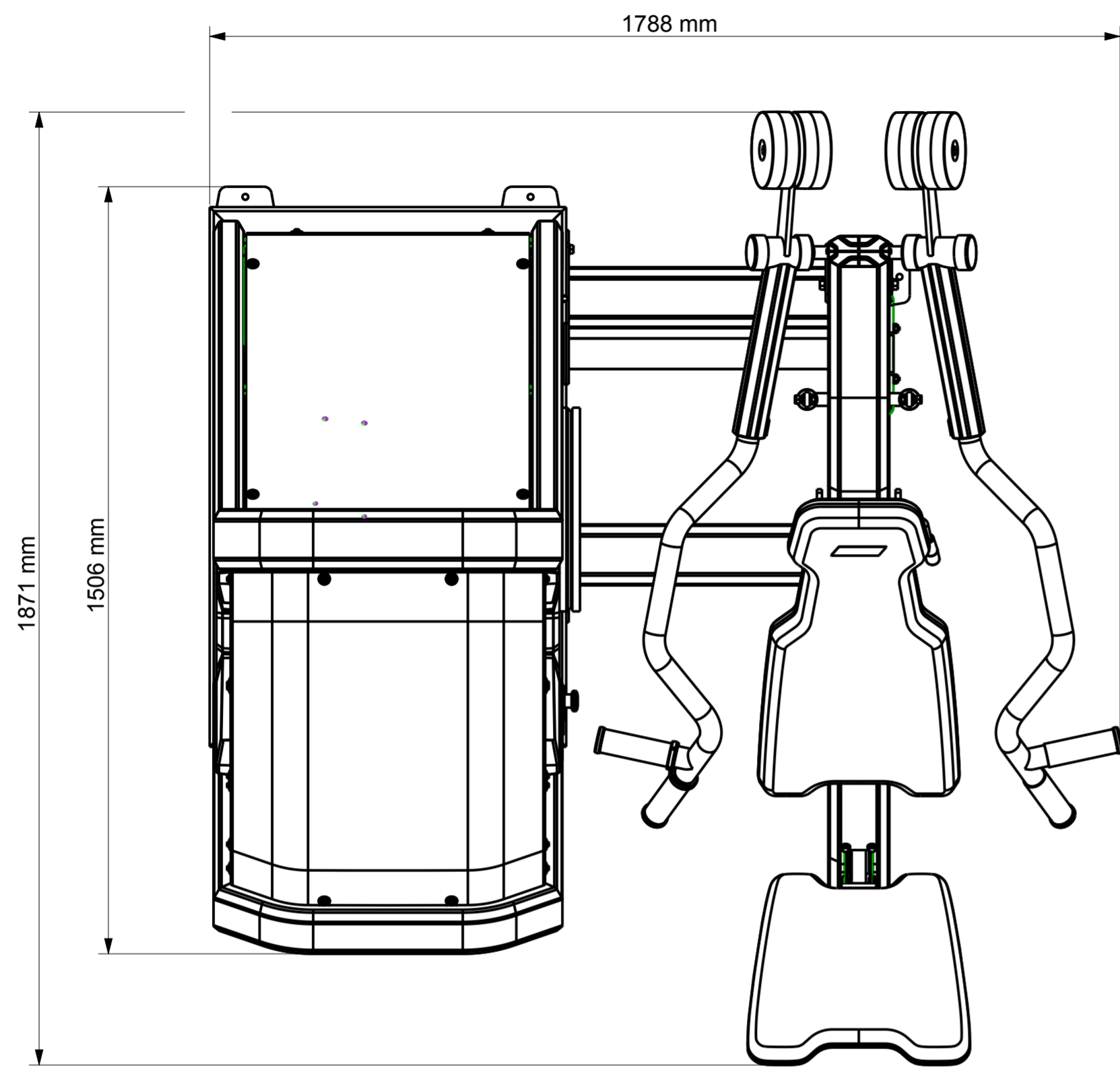
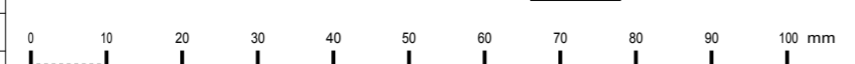

Ändring/Modification	Datum/Date	Sign