

This document is our property and must not under any circumstances be copied in its original or modified state reproduced or used for any unauthorized purpose without our written permission, nor may its contents be imparted to a third party. Contravention will be prosecuted.

PROJE designed  
No manual changes

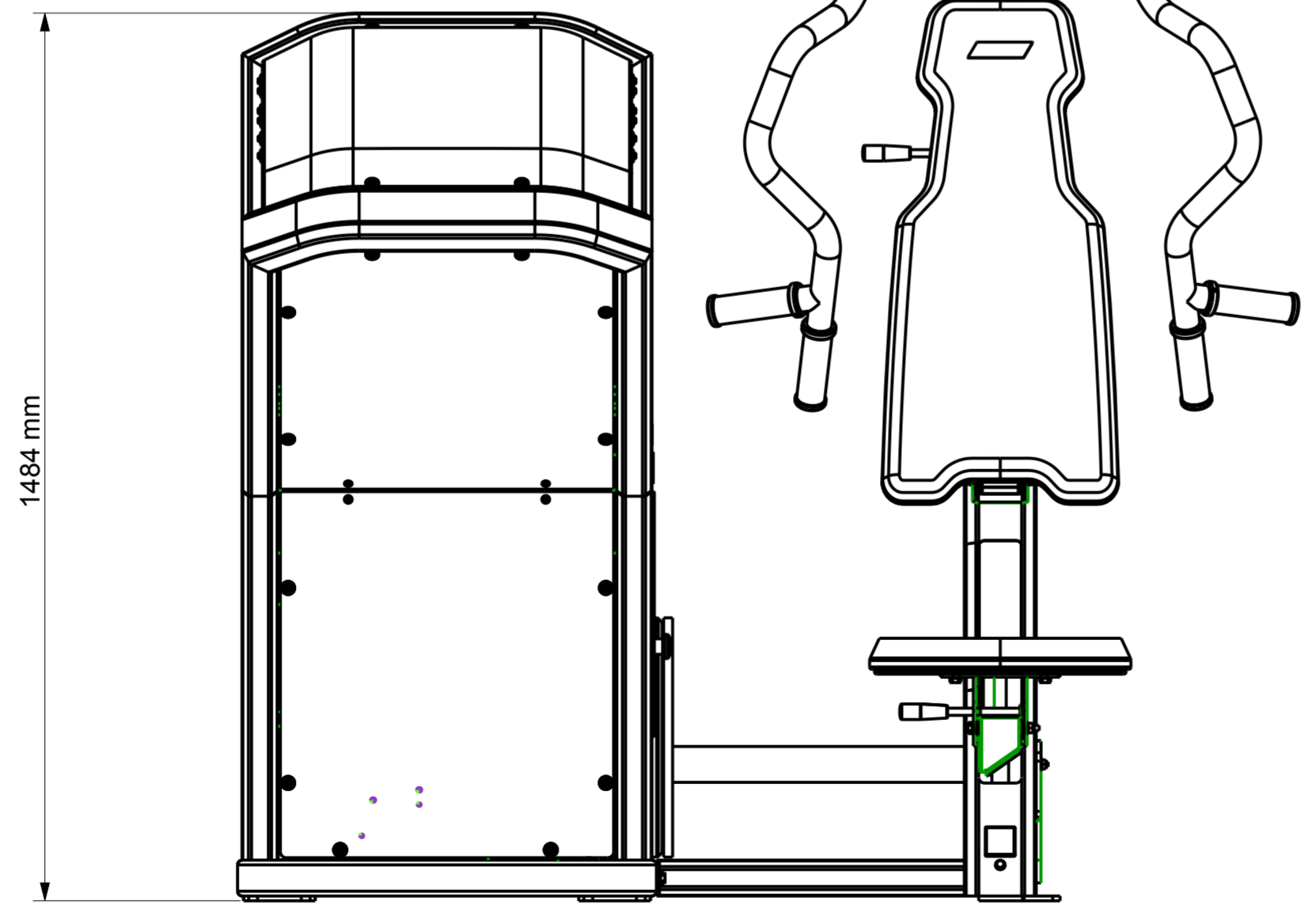

2	1	VIKTMAGASIN 18 VIKTER KORT	20500			
1	1	Pec Seated Press	20008			
Pos	Antal	Benämning	Dimension/Ovrigt	Filnamn/rtn.nr	Material/Leverantör	Anmärkning/Beställ.nr
		Denomination	Dimension/Other	File name/Drw.No	Material/Supplier	Note/Order No.
<p>Där ej annat angetts gäller följande: Unless otherwise stated the following applies:</p>						
Ytjämnhet Ra µm Surface roughness Ra µm		Ytbehandling/Suface treatment		Vikt/Weight (Kg)		
Skarpa kanter brutna Sharp edges broken		Kulör/Colour		Ersätter/Replaces		
0,2 - 0,5		ENG		Ersatt av/Replaced by		
Generella toleranser enl. / General tolerances acc. to ISO 2768-mk		Konstr./Designer	Ritad/Drawn	Kontroll/Checked	Skala/Scale	Info. klass/Classification
		OTKJ	OTKJ		1:10	
Tillämpl. std. se dok: 19990 Applicable std. see doc: 19990		Benämning/Denomination		Datum/Date	Dokumentstatus/Documentstatus	Blad nr Sheet No
		PSP		120102		1(1)
Vyplacering Proj.method		Benämning/Denomination		Rit nr Drw. No		Utgåva/Issue
					10008	K01

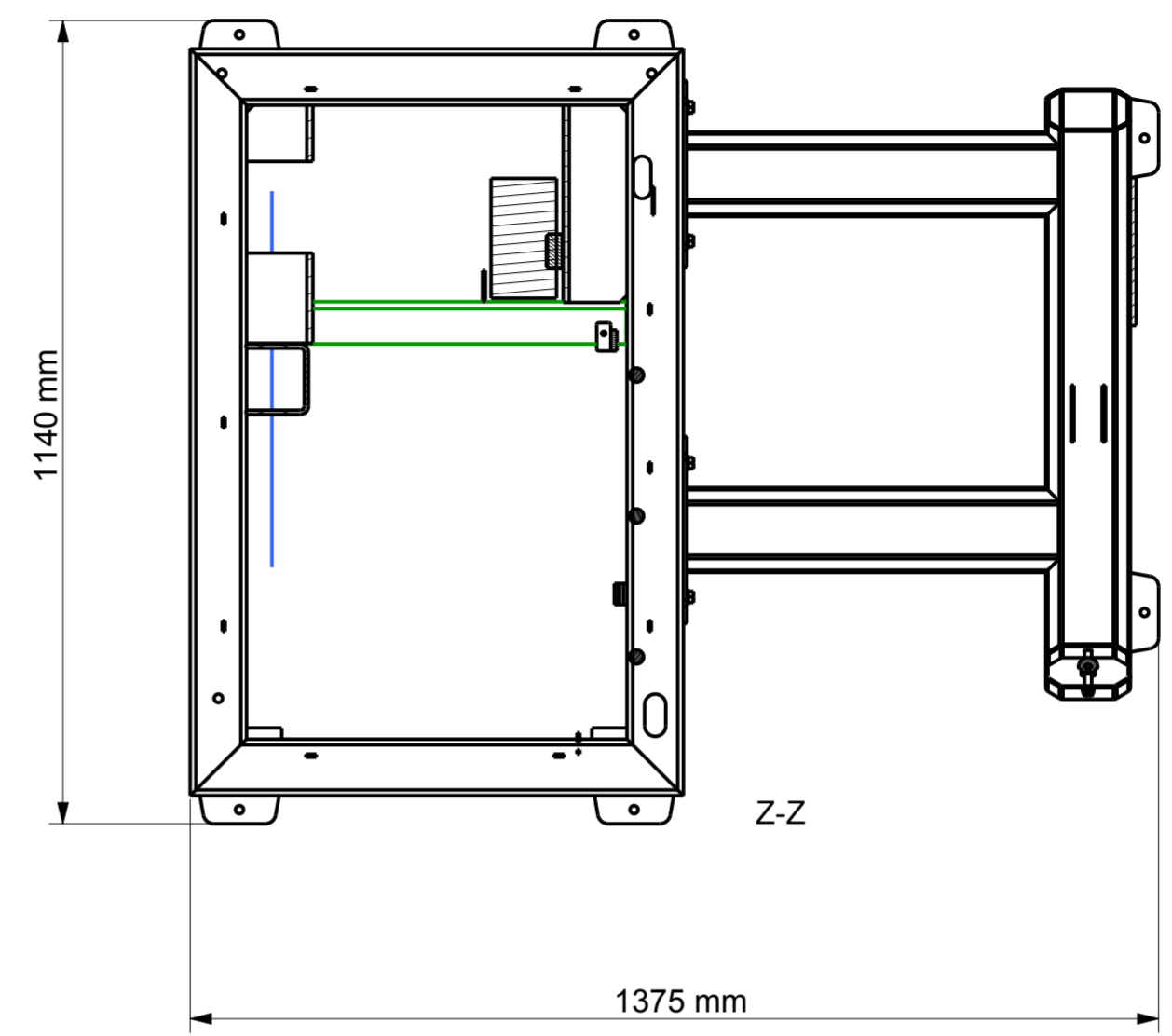
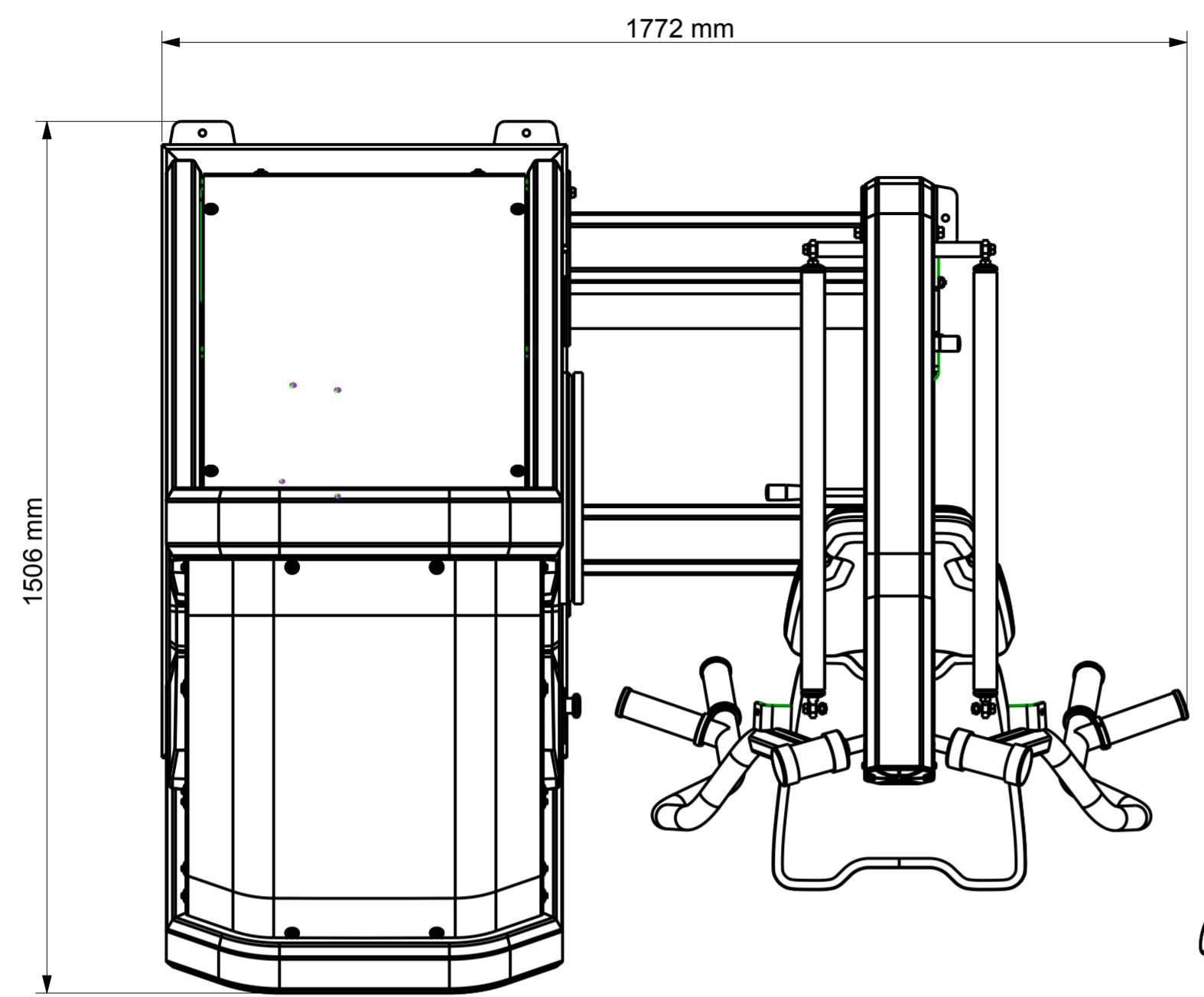